

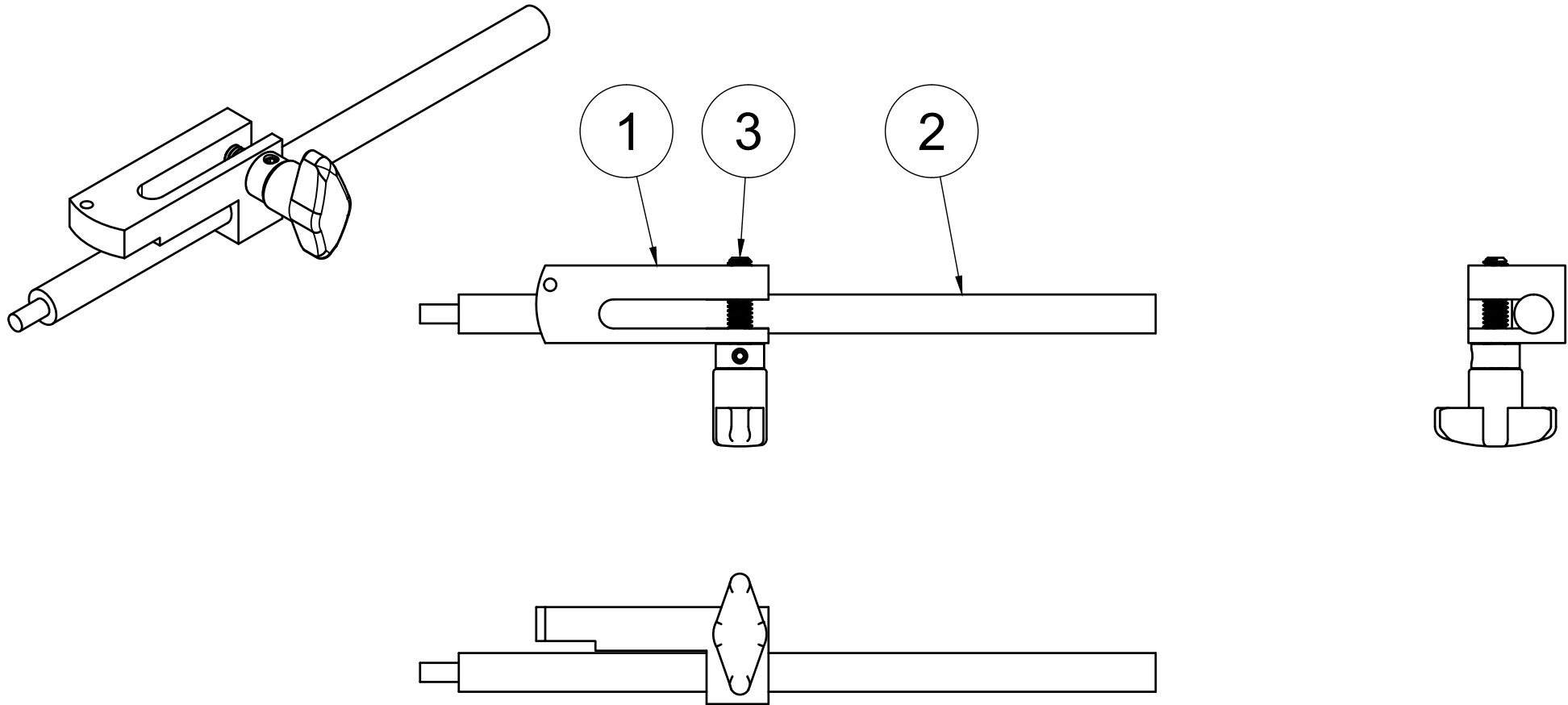

PARTS LIST

ITEM	QTY	PART NUMBER	PART NAME	DESCRIPTION	MATERIAL
1	1	GAGE BLOCK	GAGE BLOCK		ALUMINUM 6061
2	1	ROD	ROD	1/2" DIA STEEL ROD	STEEL
3	1	KNOB	KNOB	COMMERCIAL ITEM	STEEL



PROJECT	Fixtures and Tooling	TITLE	shear drop gage		DWG NO
DRAWN	2/18/23	SIZE	A	SCALE	1:2
				WEIGHT	
				REV	SHEET 1/3



PARTS LIST

ITEM	QTY	PART NAME	DESCRIPTION	MATERIAL
1	1	GAGE BLOCK		ALUMINUM 6061

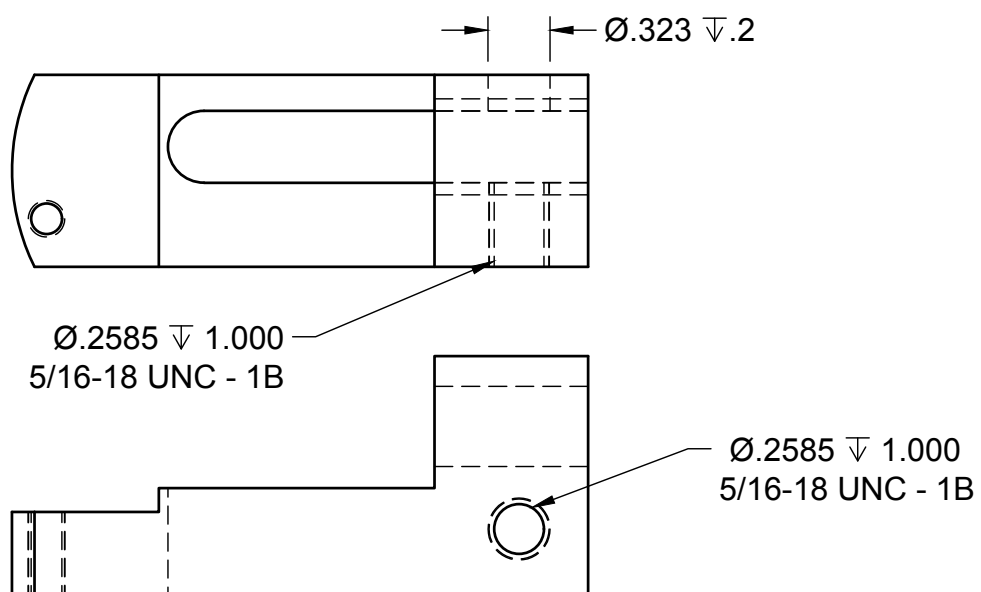
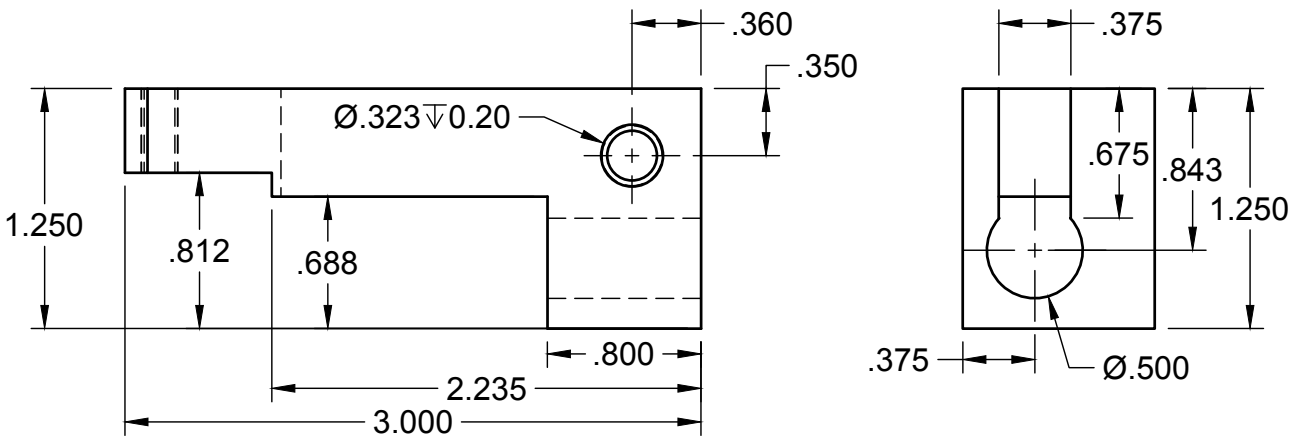
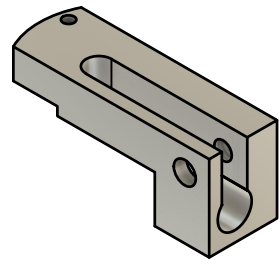
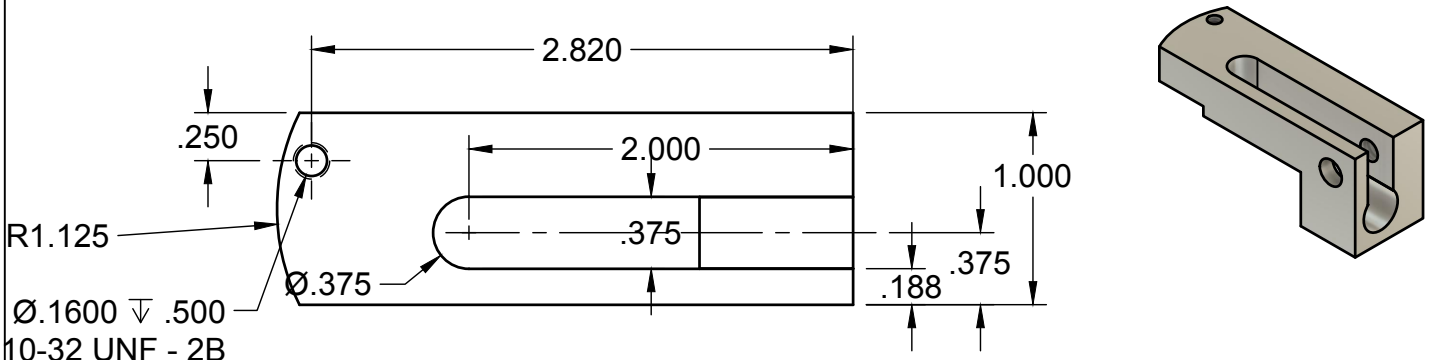

NOTES:

1. Sketch is not toleranced.
2. Purpose of 10-32 hole is unclear.
3. Purpose of front curve is unclear.
4. Fillets and chamfers left to operator.

PROJECT	Fixtures and Tooling	TITLE	shear drop gage		DWG NO
DRAWN	2/18/23	SIZE	A	SCALE	1:1
				WEIGHT	
				REV	SHEET 2/3



PARTS LIST

ITEM	QTY	PART NAME	DESCRIPTION	MATERIAL
2	1	ROD	1/2" DIA STEEL ROD	STEEL

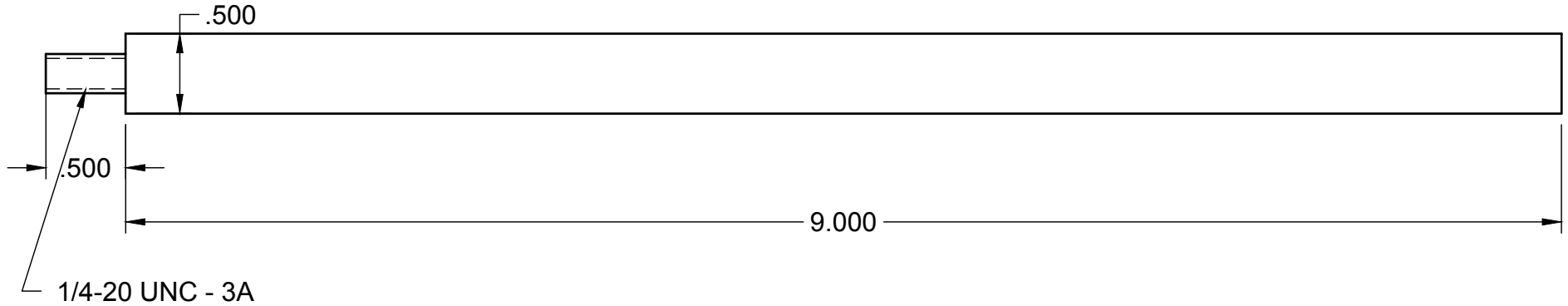

NOTES:

1. Sketch is not toleranced.
2. Nominal dimension of rod is shown. Will have to be reduced slightly to fit hole in gage block.

PARTS LIST

ITEM	QTY	PART NUMBER	PART NAME	DESCRIPTION	MATERIAL
1	1	GRAINGER 3GEK3	3GEK3 5/16 KNOB	5/16-18 X 1-1/2 T-HANDLE KNOB	STEEL
2	1	GRAINGER 36WY01	SET SCREW SHAFT COLLAR	5/16 WIDE SHAFT COLLAR FOR 5/16 BOLT	STEEL

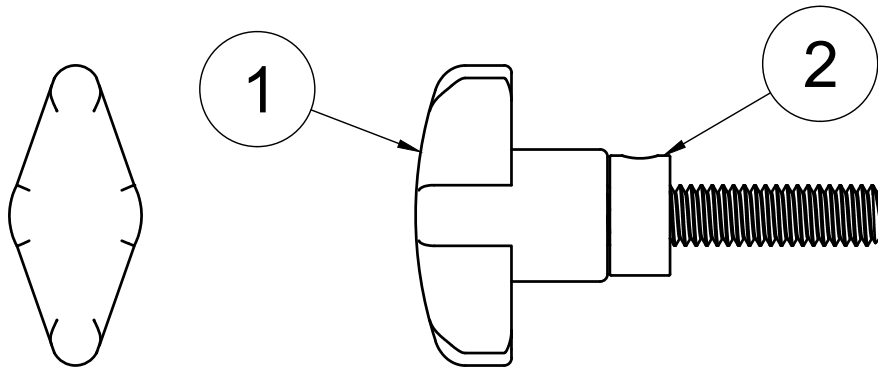

NOTE: Thread length on OEM equipment is 1-7/16.

PROJECT	Fixtures and Tooling	TITLE	shear drop gage		DWG NO
DRAWN	2/18/23	SIZE	A	SCALE	1:1
			WEIGHT	REV	SHEET 3/3

